



**400%
MORE CAPACITY
THAN DRY
EXCHANGERS**



Emeritus®





400% MORE CAPACITY THAN DRY EXCHANGERS

EMERITUS® is the new range of condensers and dry coolers created through the collaboration once again of LU-VE with Politecnico di Milano (Milan Polytechnic University).

Compared to traditional solutions, EMERITUS® unites the advantages of evaporative panels with a spray system, managed by a sophisticated control system which increases performance in all climatic conditions. Its use is ideal in:

- air conditioning systems
- industrial processes
- refrigeration systems, (especially in CO2 plant)

- **New electronic control unit**



ADVANTAGES OF EMERITUS® TECHNOLOGY

- CAPACITY +400%**
compared to dry operation
- BETTER COP**
Reduction of DT1 operation
- SILENT OPERATION**
Up to **-6 DB(A)**
reduction of sound level
- Up to **80%** reduced footprint
- Up to **95%** Reduced water consumption compared to cooling towers
- Up to **60%** less energy consumption
- INTELLIGENT CONTROL SYSTEM**
Flexible & User friendly



silencer

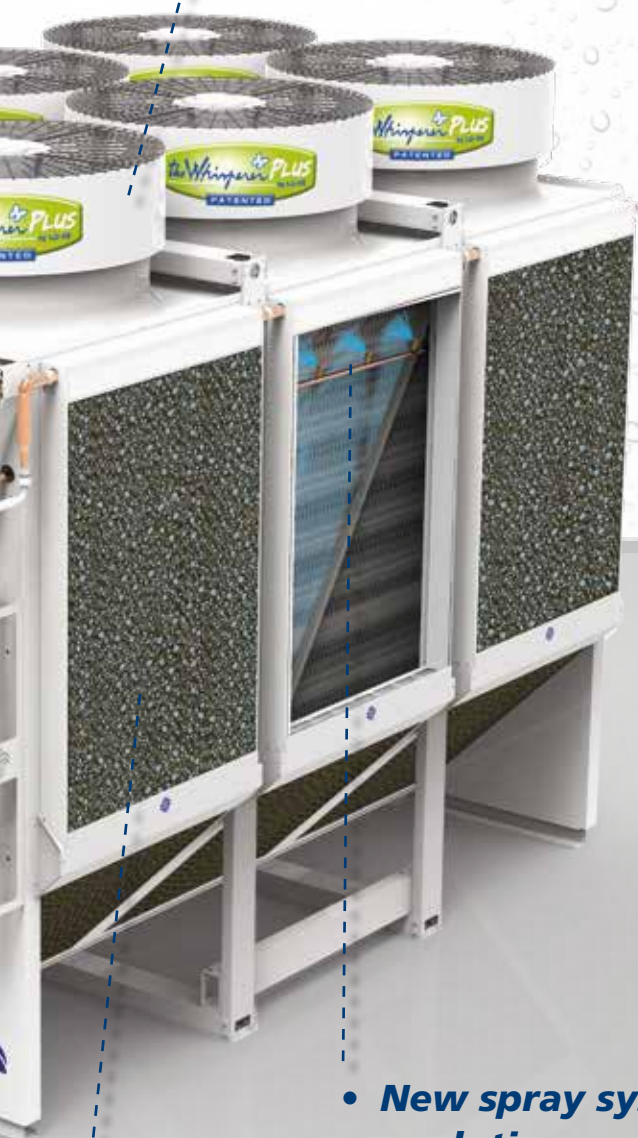

• **New spray system evolution**

• **Adiabatic system**

EMERITUS® IS AVAILABLE IN TWO VERSIONS

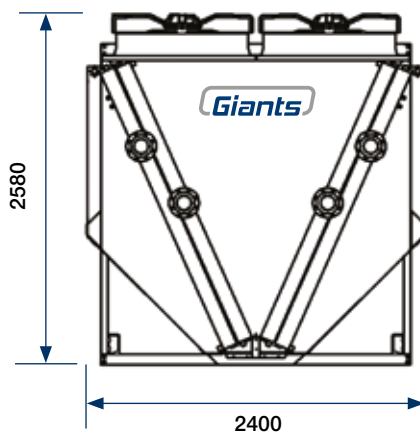

- **"GIANT"**
version for shipping by truck and in container

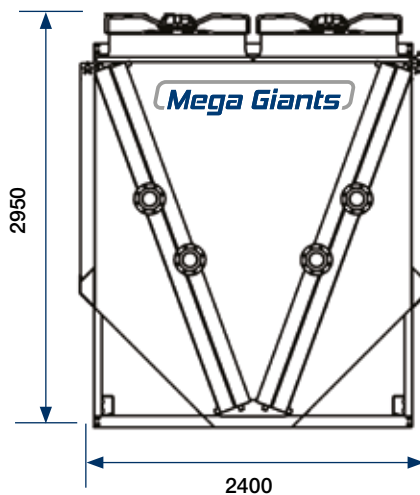

- **"MEGA GIANT"**
version to maximize heat transfer at minimum possible footprint, transportation by truck

Up to 22 fans



HOW **Emeritus**® WORKS

Emeritus® technology combines the spray function with adiabatic precooling. In this way the system exploits the synergy between two effects: adiabatic humidification and evaporation of water on the coil.

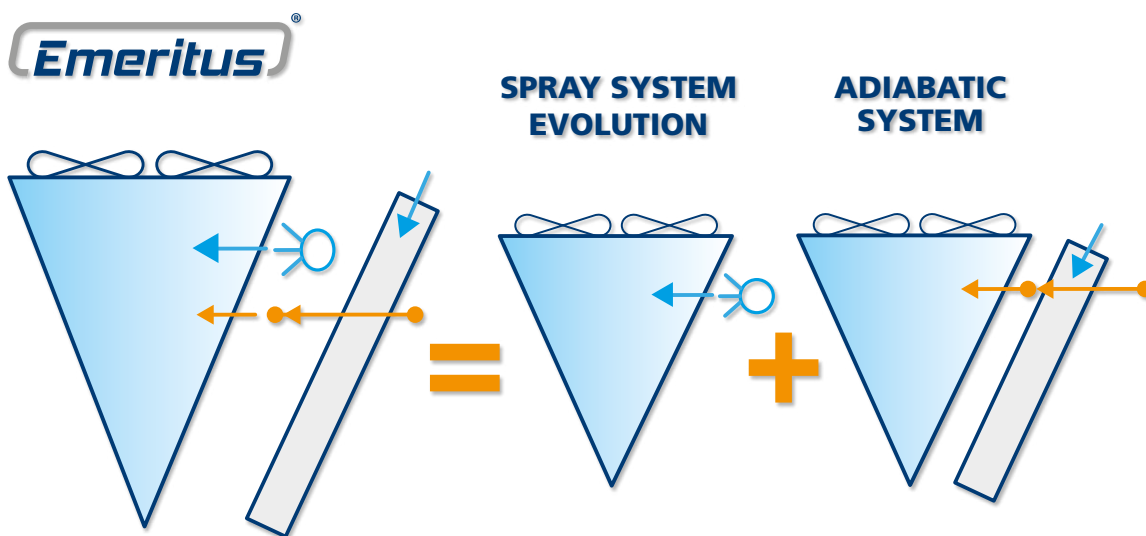

VERSATILITY OF THE SYSTEM:

Three configurations are available:

- 1 Emeritus®: Spray System Evolution + Adiabatic System**
recommended system to guarantee maximum performance
- 2 Only Spray System Evolution**
suitable for covering peaks of temperature
- 3 Only Adiabatic System**
suitable for systems without water treatment

The Emeritus® system is patent pending.

OPERATION

The combined Spray System + Adiabatic System mode operates as follows:

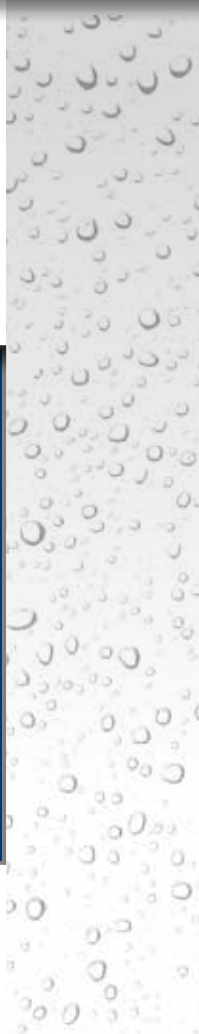
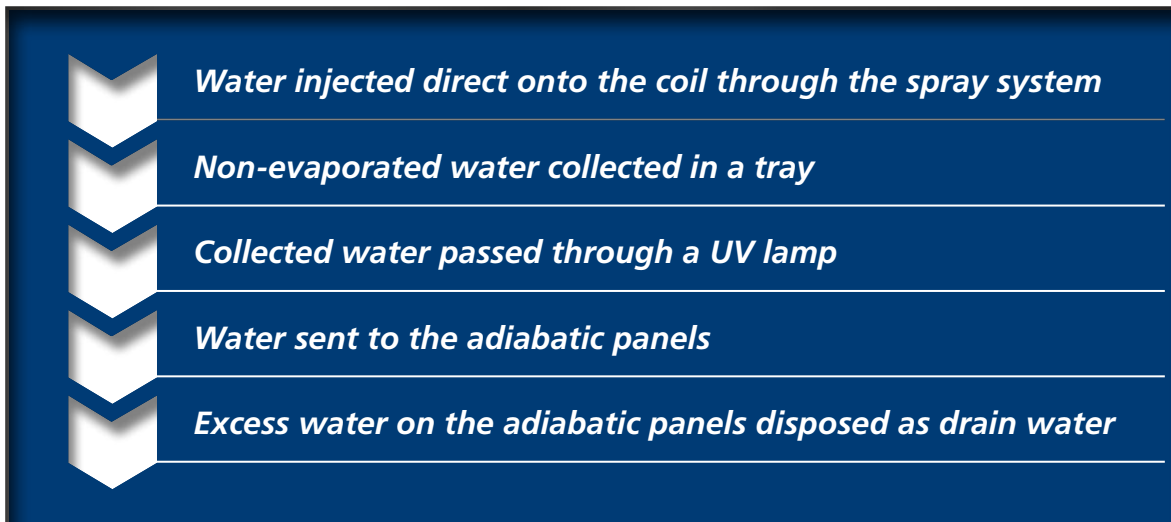

PERFORMANCE RANGE COMPARISON

Emeritus® can operate with 2 objectives:

- 1 • Increased capacity at equal footprint
- 2 • Increased COP at equal sound level

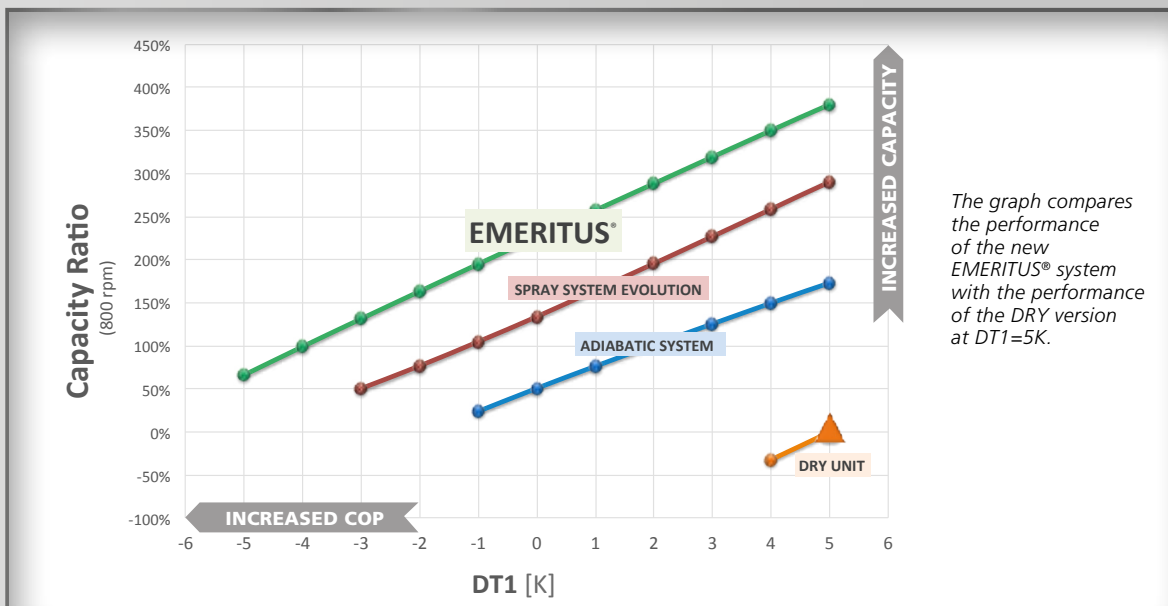

DT1 = liquid inlet temperature – air inlet temperature (dry bulb)



COMPARISON OF DIFFERENT SOLUTIONS AT EQUAL SOUND LEVEL

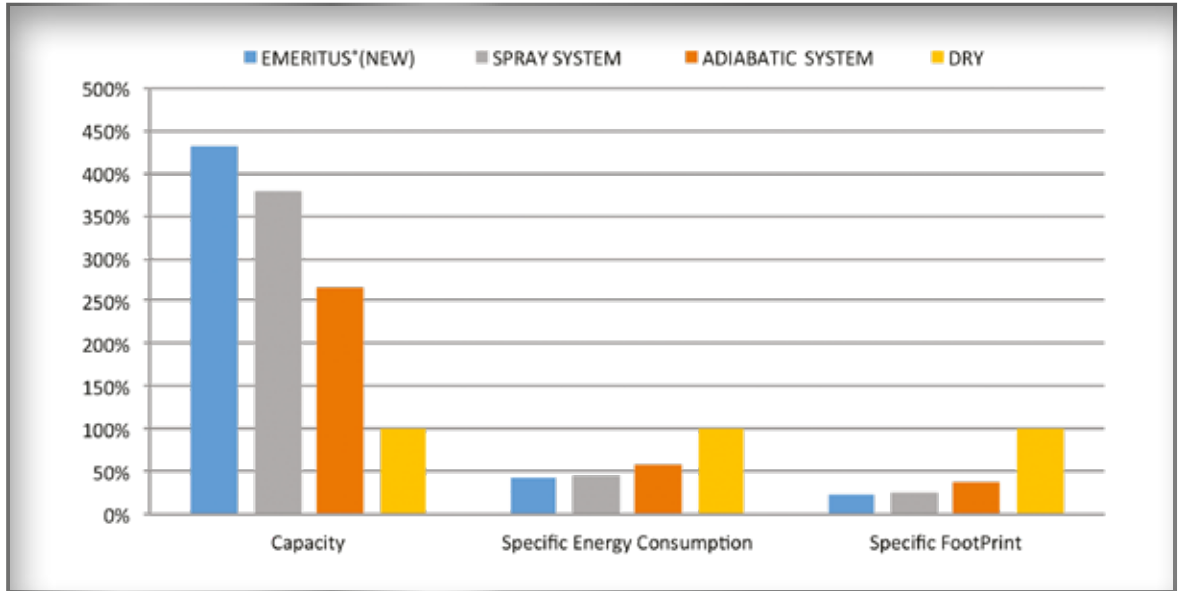

The capacity increase starting from the dry system is very significant. Specific power draw is greatly reduced ensuring energy saving up to 60% compared with a dry unit. Important reduction of footprint (up to -80%).

MAIN ADVANTAGES

Greater capacity - Energy efficiency - More compact machines



Emeritus® SOLUTIONS FOR NH₃

Improving performance of ammonia condensers

TARGETS

- **INCREASED COP**
- **REDUCED AMMONIA CHARGE** (more than 50% compared to dry operation)
- **REDUCED OPERATING COSTS & WATER CONSUMPTION**

More than
50%
Reduction
of ammonia
charge

NH₃

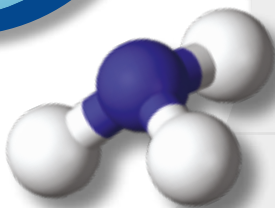

SOLUTIONS FOR CO2

Application of adiabatic system technology to gas coolers

Emeritus® can offer benefits in the sector of CO2 transcritical supermarkets. The ability to use just the adiabatic system in the absence of a water treatment plant is a further example of its versatility. The system offers the following benefits:

The graph shows the performance levels of a gas cooler with Adiabatic Panel technology compared with a traditional dry system. The technology with adiabatic system shows clearly superior performance.

At equal capacity, it is possible to bring the CO2 outlet temperature down from 40°C to 30°C.

A reduction of 10 K of the CO2 has a positive consequent impact on the COP of the system.

In a comparison made at equal conditions (the same capacity, the same evaporation temperature, etc.), a COP increase of **69%*** was obtained.

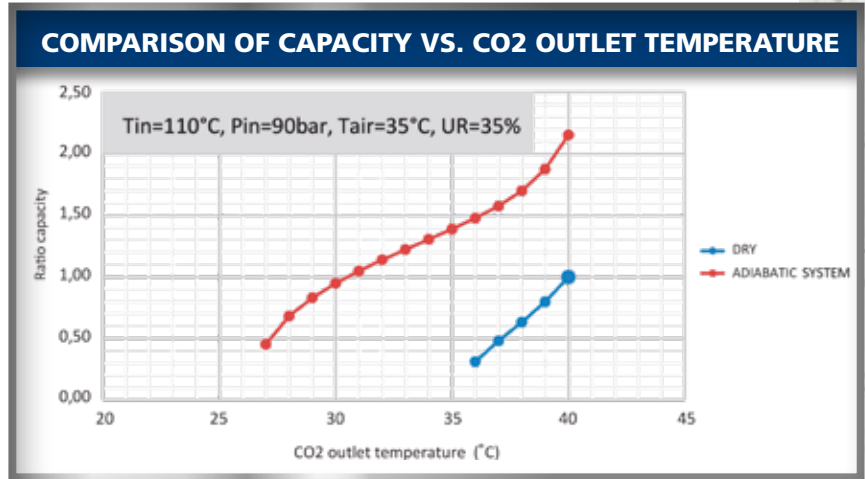

*hypothesis of a simple cycle with evaporation temperature of -8°C. The COP goes from 1.31 (temp. Tout CO2 gas at 40°C) to 2.21 (T.out CO2 gas at 30°C)

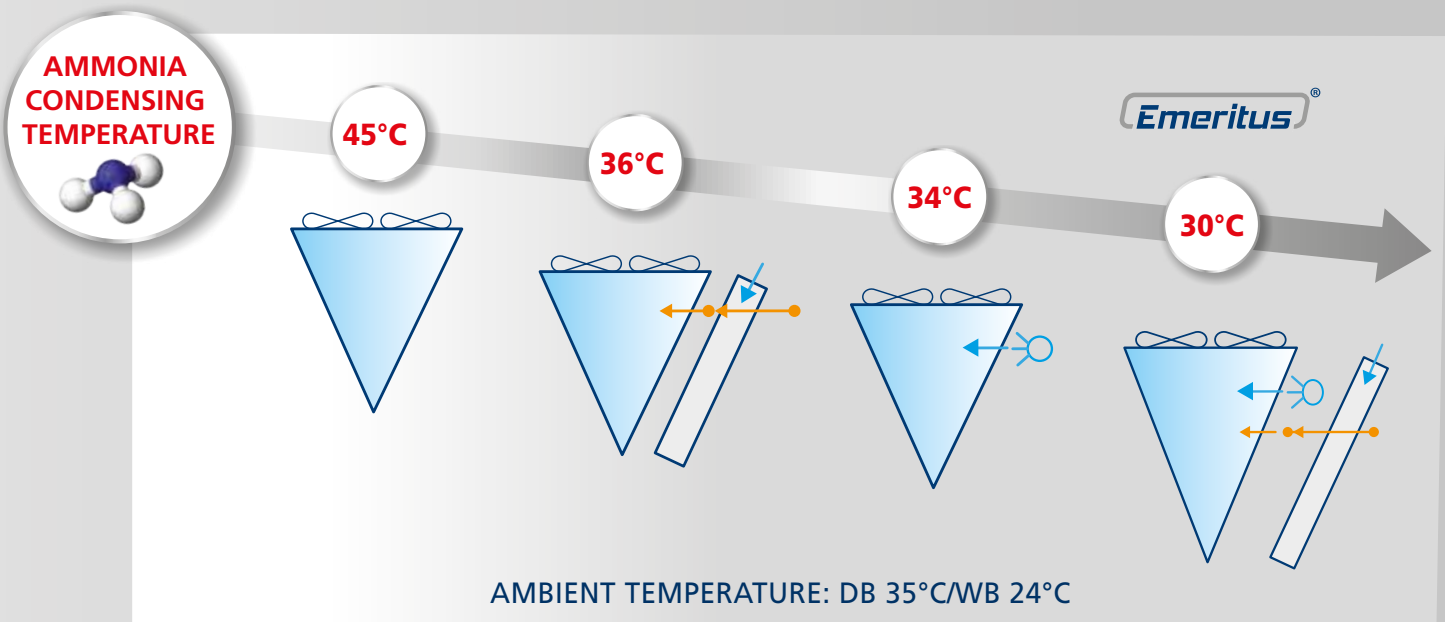

15K REDUCTION at equal capacity and equal sound level



REDUCED WATER CONSUMPTION

Using **EMERITUS**[®] dry coolers and condensers as an alternative to the traditional cooling towers and evaporative condensers has an important advantage in water consumption.

ANNUAL WATER CONSUMPTION (INDUSTRIAL PLANT)



Up to
95%
Reduced water
consumption
compared to
cooling towers



BETTER PROTECTION

To ensure maximum protection of the heat exchanger surfaces, Emeritus[®] uses water with these characteristics:

	EU Directive 98/83/EC on drinking water	EMERITUS [®] specification
Conductivity [μ S/cm]	<2500	<800
Fixed residues [mg/l]	<1500	<500
Chlorates [mg/l]	<250	<100
Sulphates [mg/l]	<250	<50
Hardness [°f]	<50	4-6
Indicative softener ratio (max)	-	7
pH	6.5 - 9.5	6.5 - 8.0

TWO FURTHER IMPORTANT PROTECTIONS:

ACTIVE

Sensors to check the quality of the water

To make sure that the water is always within the pre-set limits, Emeritus® has 2 sensors which constantly measure these parameters:

- pH
- electrical conductivity

The data are memorized by the control system and in the event that the threshold limit is exceeded the controller sets off an alarm, the water supply is then interrupted.

PASSIVE

ALUPLUS®: a new magnesium-aluminium alloy coated with a special paint treatment to give strong protection and resistance to corrosion.

The severe tests carried out in salt spray conditions showed that the ALUPLUS® fin is

TWICE as resistant as ALUPAINT® solution.

WET WORKING TIME

Emeritus® can work in wet operation for a different number of hours per year for each configuration:

	hours / year	ALUPLUS®	WATER TREATMENT
1 EMERITUS®: Spray system + Adiabatic system	~2000	Required	Required
2 Only spray system evolution	300	Required	Required
3 Only adiabatic system (no water treatment)	no limits*	Optional	Optional

**in relation to the ambient conditions and the correct integrity of the adiabatic panels*



Emeritus[®]

NEW ADVANCED CONTROL SOFTWARE

Through a **sophisticated regulation system**, combined with EC fans, the function of EMERITUS[®] is optimized based on operating conditions, with consequent **energy savings**.

The wide application field and the setting of numerous operating configurations is closely tied to a new sophisticated control software.

The non-evaporated water from the coil is used to supply the adiabatic panels with reduced water consumption.

The new *ad hoc* software implements advanced functions which can be optimally adapted to all kinds of plant.

DOUBLE SET POINT:

- **Fixed set point:** the fixed point is set once for all and the system adapts to follow it (Industrial applications)
- **Floating set point:** varies as a function of the external temperature and allows energy savings thanks to the continuous searching for the best working point (Air conditioning applications)

TWO REGULATION MODES:

- **Proportional:** set point coincides with the maximum reachable value
- **Incremental neutral zone (PID):** the controller adapts the operation of the machine to maintain the set point around the design value.





FUNCTIONS

- **Interactive menu, language selection**
- **Water quality check**, active control with pH and electrical conductivity sensors
- **Antilock of the fans** in the event of extended very low external temperature
- **Coil cleaning** by reversing the rotation direction of the fans
- **Coil washing** (programmable) by spraying water with motors off
- **Winter function** to switch off fans to optimize capacity at very low external temperatures
- **Anti-Icing**: manual, timed, water drainage from remote inlet, based on ambient temperature
- **Operating pressure check** warning level and alarm with possible system arrest
- **Remote monitoring** with Modbus RS485 port, Ethernet port, USB, connection to customer BMS
- **Silentmode** can be set for time slots
- **Check of total spray and adiabatic panels operating hours**
- **Remote Supervising**: It is possible to define with the customer a remote connection to LU-VE using internet or GPRS system
- **Data logger** stores the main working parameters for an operation period of up to 10 years

LEADERSHIP WITH PASSION



LU-VE Group is an international enterprise with its headquarters in Uboldo, Varese, along with its main offices and principle production facility. The strength of the Group lies in its 12 production plants located in 8 different countries Italy, China, Czech Republic, India, Poland, Russia, Sweden and USA. The companies which make up the Group are:



LU-VE Sweden AB - Sweden

Air cooled heat exchangers for commercial and industrial refrigeration, air conditioning and industrial applications.



HTS s.r.o. - Czech Republic

Heat exchangers for special applications, air conditioning and refrigeration, air cooled condensers.



LU-VE Digital - Italy

Information technology, development and implementation of calculation software, on-line activities and IoT (the Internet of Things).



LU-VE S.p.A. - Italy

Air cooled heat exchangers for commercial and industrial refrigeration, air conditioning and industrial applications.



LU-VE Heat Exchangers Ltd. - China

Air cooled heat exchangers for commercial and industrial refrigeration
Heat exchangers for special applications, air conditioning and refrigeration, air cooled condensers.



SEST S.p.A. - Italy

European Leader in the production and sales of static evaporators for refrigerated counters and display cases, and heat exchangers for various applications.



SEST LU-VE Sp. Z.o.o. - Poland

Static evaporator coils for display cabinets, bottle coolers and chilled beams.



“OOO” SEST LU-VE - Russia

Static evaporator coils for display cabinets, bottle coolers and chilled beams, unit coolers.



TECNAIR LV S.p.A. - Italy

Close control air conditioners for surgical rooms, white rooms, data centres and telephone exchanges.



TGD - Thermo Glass Door S.p.A. - Italy

Glass doors and closing systems for professional, industrial and domestic refrigeration equipment.



SPIROTECH Heat Exchangers Pvt. Ltd. - India

Heat exchangers for domestic appliances, air conditioning and refrigeration.



Zyklus Heat Transfer, Inc. - U.S.A.

Heat exchangers for special applications and for the air conditioning and refrigeration sectors.

LEADERSHIP IN ACTION



Heat exchangers for industrial and commercial refrigeration, air conditioning and industrial applications.

LU-VE S.p.A. is the holding company of LU-VE Group. In 1985 LU-VE S.p.A. acquired Contardo S.p.A., established in 1928. Production began in 1986.

LU-VE quickly made its mark thanks to high standards of quality, new solutions designed in its own laboratories and to the care taken with the appearance of its products. (Beautiful outside - Revolutionary inside).

It was the first company in the world to apply avant-garde solutions to commercial and industrial refrigeration:

- grooved tube technology;
- specialized heat exchange surfaces;
- certified performance levels;
- innovative materials and colours;
- advanced design.

The success of LU-VE in the international market stems from its research and development policy, its great respect for the environment and its rigorous ethical and commercial principles.

In 2000, LU-VE was the first company in Europe to attain the prestigious Eurovent "Certify-All" certification for the entire range of its products: unit coolers, condensers and dry coolers.

LU-VE and the Group have introduced new ways of conceiving and constructing products for refrigeration, air conditioning and industrial applications, creating new technologies which have then gone on to become the benchmark for the entire industry.

Blank lined page with horizontal ruling lines.



LU-VE
GROUP
leadership with passion

www.luvegroup.com



LU-VE
exchangers

www.luve.it